

---

**Global Renewable Energy Forum**  
**Foz do Iguacu, Brazil, 18-21 May 2008**

**Wind Energy in the World.**  
**Russian Wind Energy Systems**

**Dr. Sergey V. Gribkov, World Wind Energy  
Associatiozn WWEA, WINDEC Research Cener,  
Moscow, Russia**

**Dr. ac. RANS, Ildar R. Utiamyshev, Russian Academy  
of Natural Sciences RANS, Moscow, Russia**

---

# World Wind Energy 2006

- 67 countries
- Installed wind power plant generation power 73940 MWt
- Power generation increase in 2006 – 149000VWt – 25%

## WORLD LEADERS

№	Country	2006г, MWt	В 2006г, MWt	Growth, %
1	Germany	20 622	2 194	11,9
2	Spain	11 615	1 587	15,8
3	USA	11 603	2 454	26,8
4	India	6 270	1 840	41,5
5	Denmark	3136	8	0,3

# Countries which have installed WE power generation exceeding 1000 MWt (total 13)

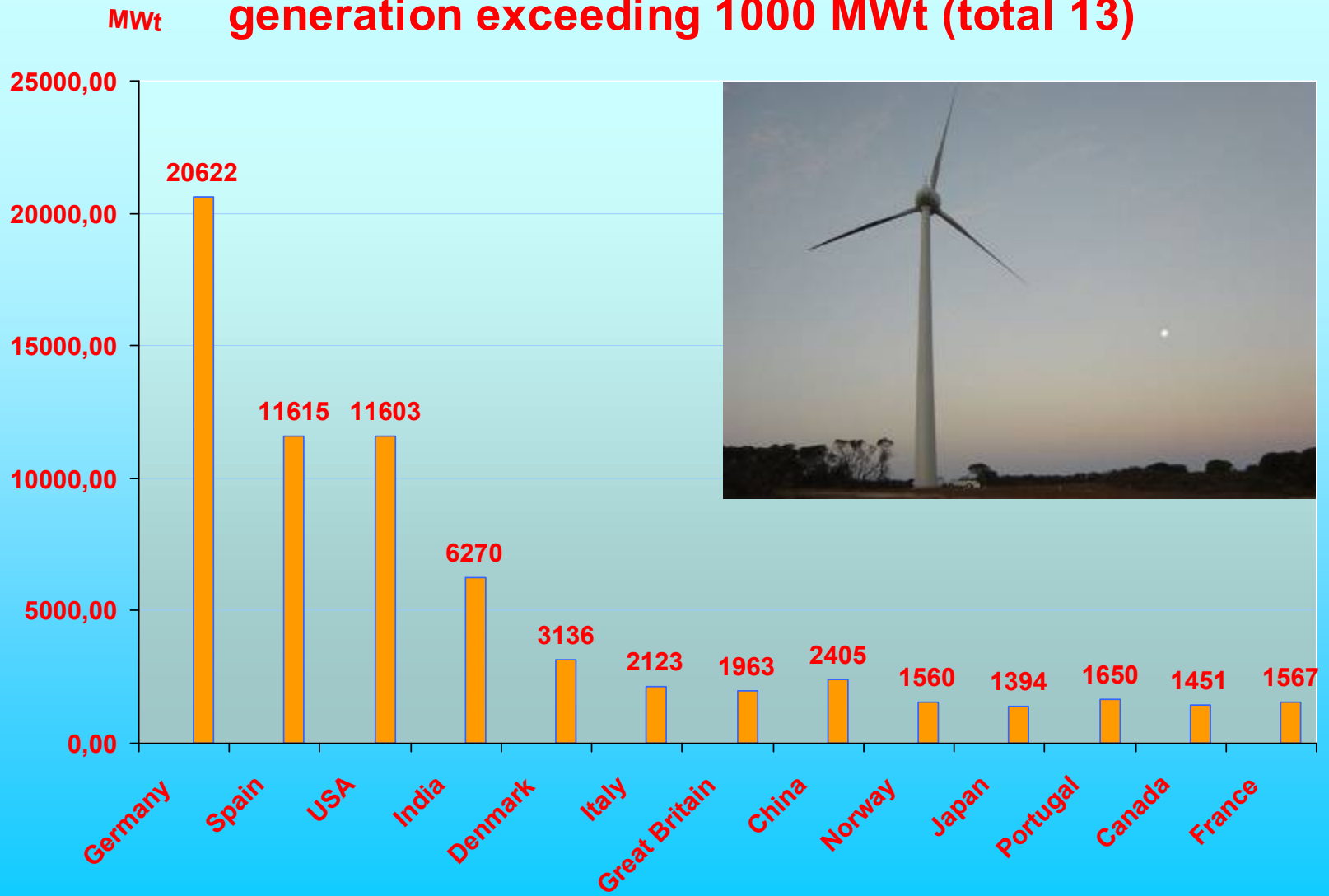

# WE generation power distribution in different continents in 2005

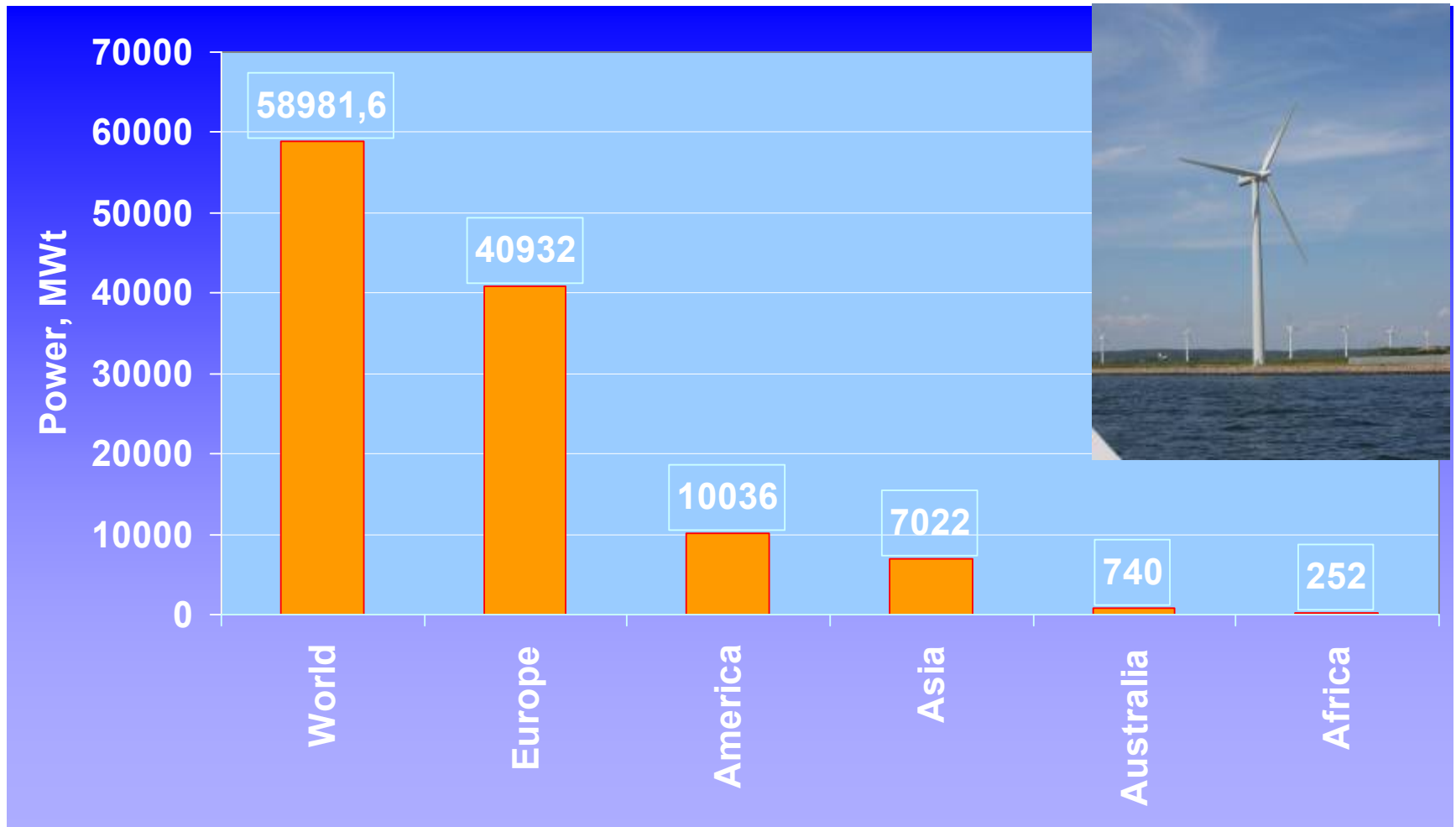

# WE generation growth in 2005 and 2006

Company	Country	% of World market, 2005	% of World market 2006
Vestas	Denmark	27,9	27,4
GE Wind	USA	12,9	17,7
Enercon	Germany	14,2	14,5
Gamesa	Spain	12,9	15,5
Siemens	Germany	5,5	7,1
Repowerer	Germany	3,2	3,2
Nordex	Germany	2,5	2,9
Mitsubishi	Japan	2,0	1,6
Suzlon	India	6,1	7,5



# Wind energy development in past 25 years

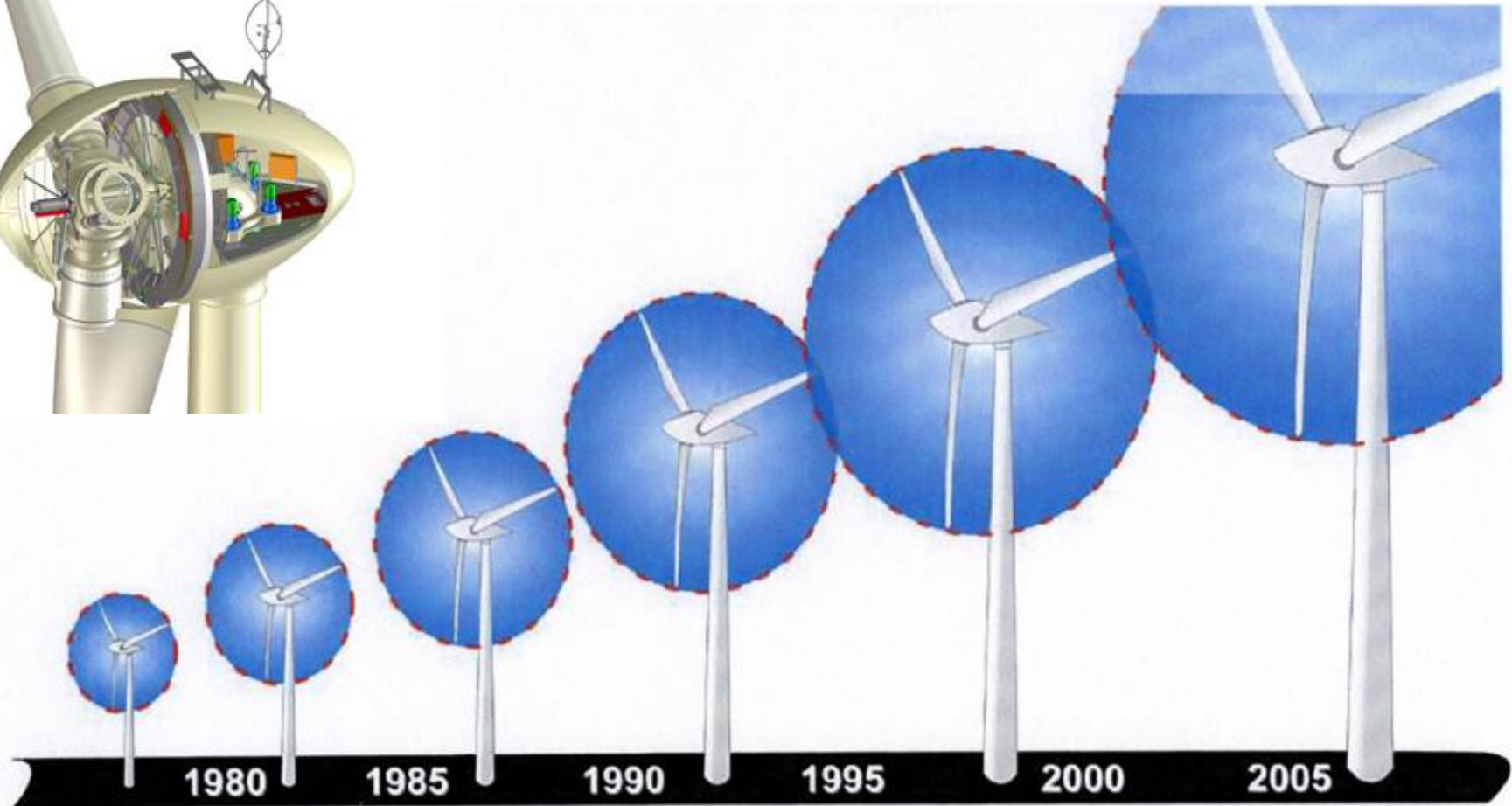
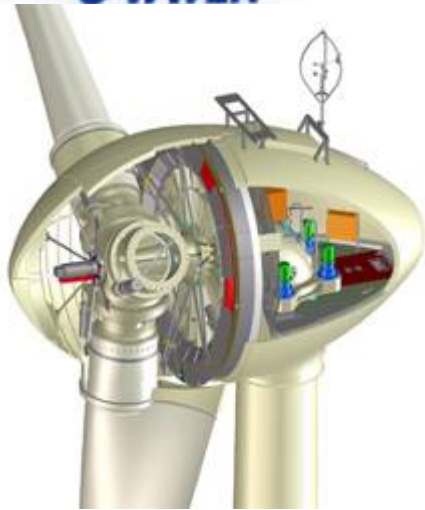

	1980	1985	1990	1995	2000	2005
<b>Power</b>	30 kW	80 kW	250 kW	600 kW	1.500 kW	5.000 kW (Offshore)
<b>Rotor</b>	15 m	20 m	30 m	46 m	70 m	115 m
<b>Axis height</b>	30 m	40 m	50 m	78 m	100 m	90 m
<b>Annual generation</b>	35.000 kWh	95.000 kWh	400.000 kWh	1.250.000 kWh	3.500.000 kWh	ca. 17.000.000 kWh

---

# WE Development Prospects

- In Europe in 2020 WE power plants will produce 20 % of total electric power (at present – 6 %)
- In Germany in 2015-2020 – 20 %
- In Denmark in 2015 – 25 %

## Ecological aspects

1 MWt of WE prevents blow up of 2 th. Tons of CO<sub>2</sub>,  
15 tons SO<sub>3</sub>, 2 tons NO<sub>x</sub>  
Saving 1-3 th. Tons of relative fuel

---

# Russia wind potential map

Annual wind potential of Russia  $6.2 \times 10^{15}$  KWt Hour

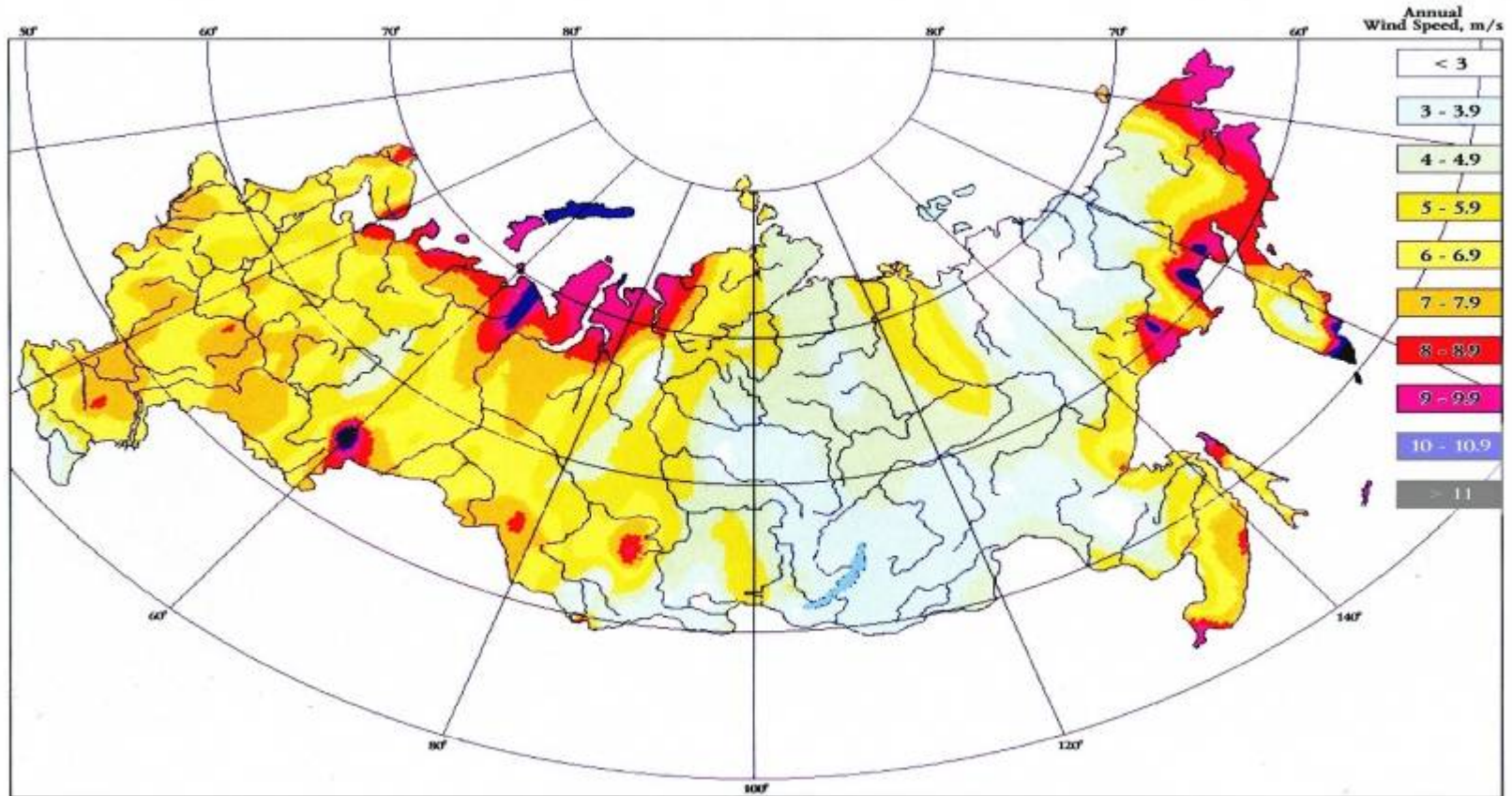

---

# **Russian wind energy power plants (WEPP) and installations**

- **Vorkuta WEPP 1.25 MWt (250 KWt X5)**
  - **Kalmyk WEPP (1 MWt x2)**
  - **Kulikov WEPP 5..1 MWt (21 WE installations)**
  - **Anadyr WEPP ( 250 KWt x 10)**
  - **Bashkir WEPP (550 KWt x 2)**
  - **Bering island 0.5 MWt (250 KWt x 2)**
  - **Rostov 0.3 MWt (30 KWt x 10)**
-

---

## **Russian Federation Federal Law 4 November 2007 No 250, Addition to legislation acts of the Russian federation according to the United Energy System of Russia (RAO UES) Reformation**

### **Paragraph 21**

- **According to the legislation of the Russian Federation for power sector the Government of the Russian Federation provides a support of renewable power sources implementation and stimulation energy efficiency technologies in accordance with budget legislation of the Russian Federation**
  - **Approves the criteria of federal budget subsidies in order of technical connection cost compensation for generation objects less than 25 MWt accepted by qualified objects according to p1 of the paragraph 33 of present Federal law operating on the basis of renewable power sources application and for persons having this objects in ownership or other legal basis.**
-

---

# **Application of WE power systems for guaranteed of law power consumption 0.2 –05 KWt**

- Agriculture farms
  - Telecommunication systems
  - Power supply of energy crisis objects and extraordinary situation regions
  - Military objects and frontier posts
-

## Block- scheme of WE power plant 50 –50 Wt

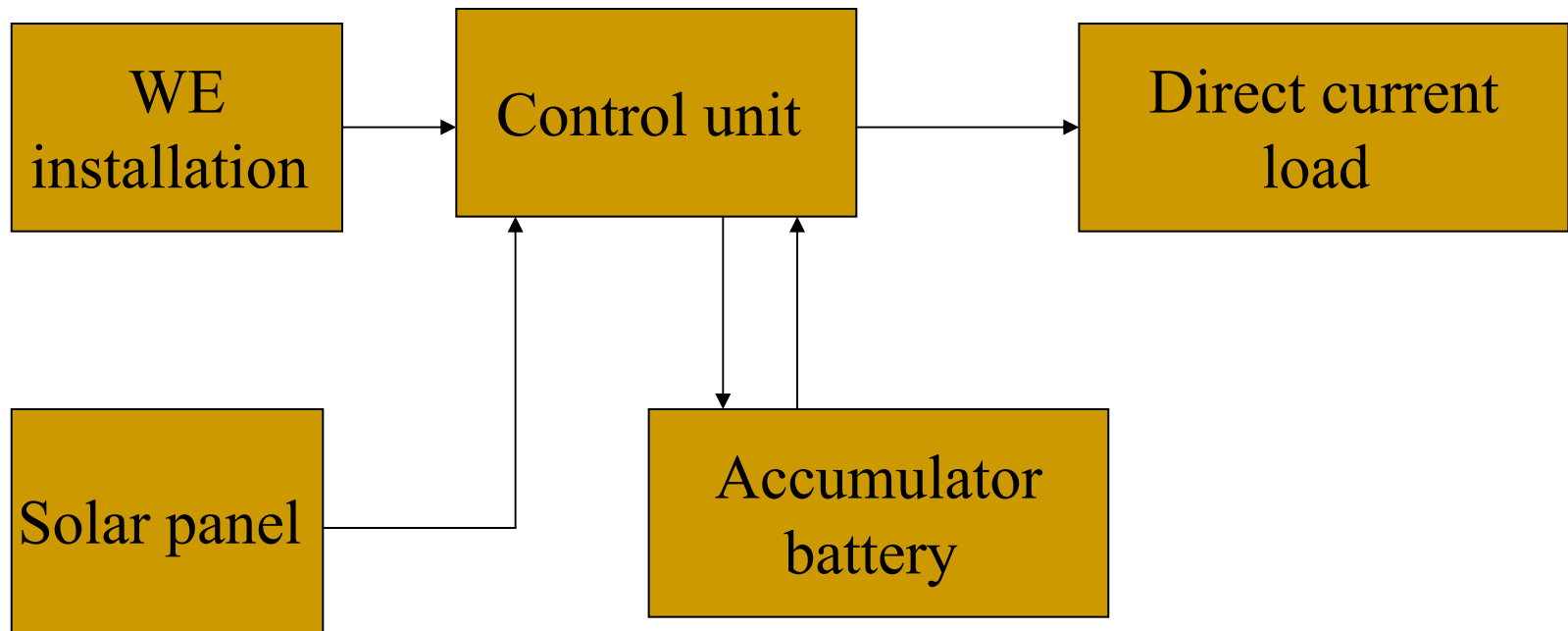

Application: power supply for electronic devices and diode light sources

## Block – scheme of WE power plant 0.5 – 5 KWt

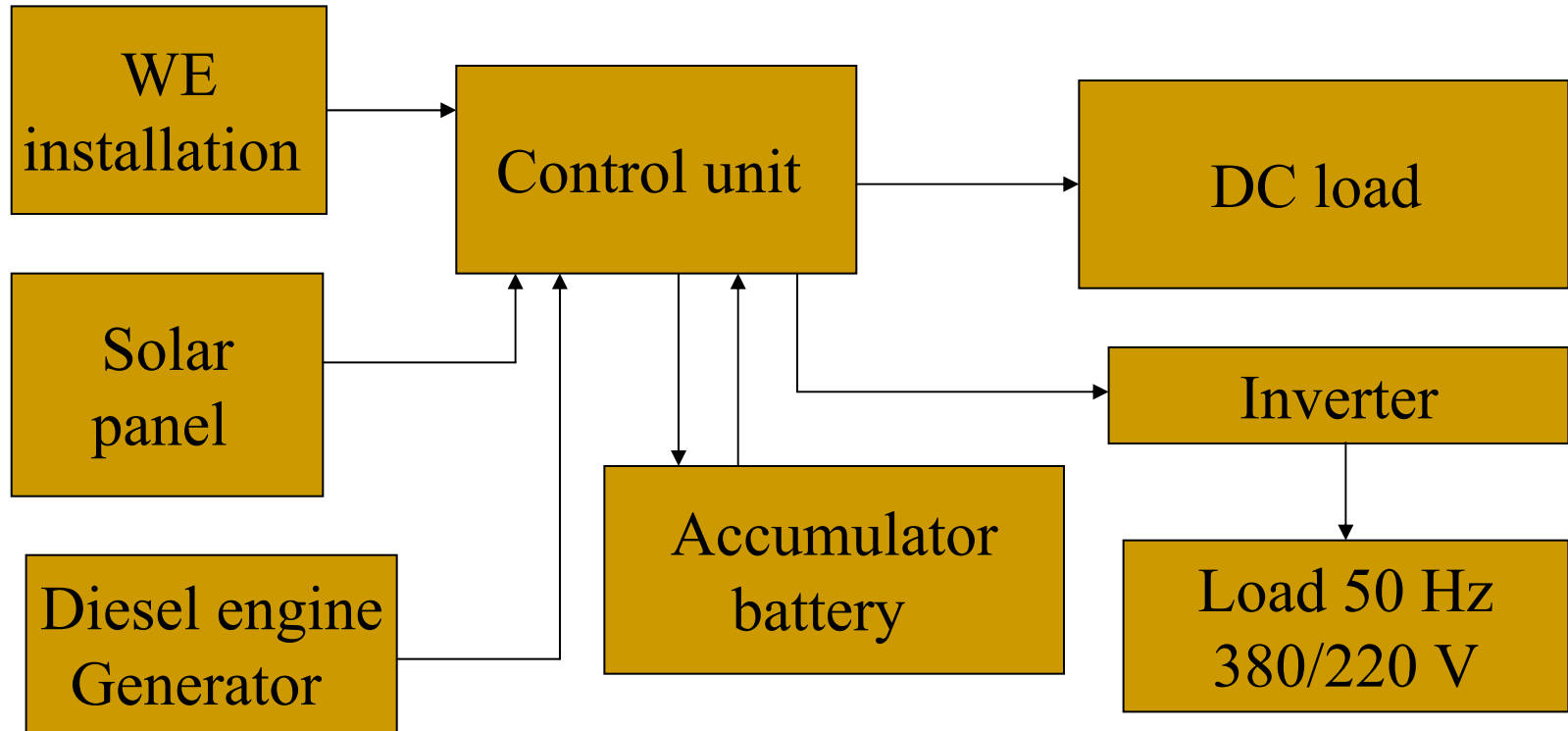

# Federal enterprise ELECTROPRIBOR, Saint Petersburg

**WE system UVEU-05**  
**05....1.5 KWt**



# VETRO-SVET Co, Saint Petersburg

200 Wt



# Moscow Machinery Plant VPERYOD

WE installation FORWARD-05



# SAPSAN, Moscow



# SAPSAN, Moscow



# SPETSREMTEKH – ATIKA , Moscow

**WE installation 2 KWt**



# Research Center WINDEC, Moscow

WE installation VEU-0



# Research Center WINDEC, Moscow



1 kWt



**VEU-1 WINDEC  
Tajikistan  
Pamir mountains  
Frontier posts  
Power source for  
cellular telephone  
station**



**VEU-02 WINDEC**

**200Wt**

**$V$  calculated = 7 m/s**

ID ELECTRIC  
TEN OIG



# VETROSTAR Ltd, Ekaterinburg

- **VEU –5-4**
- **P = 4.2 KWt**
- **V working = 4 – 25 m/s**
- **D rotor = 5 m**



# ELECTROSPHERA, Saint Petersburg

Briz-5000, 5 KWt



# Russian Research Institute for Electromechanics, Istra

**VTEN – 8 – 10**



# MOSCOW OZONATORS, Moscow

Lark  
30 KWt



# Moscow Machinery plant VPERYOD, VETROSTAR Ltd

Water disalinator



VEU – 16/30



# VETROENERGETICA Co, Volgograd

**P = 20 - 80 KWt**



# Federal enterprise RADUGA

Raduga-008

P = 8 ...30 KWt



# Lianozovo electromechanical plant

VDEU – 30

30 KWt

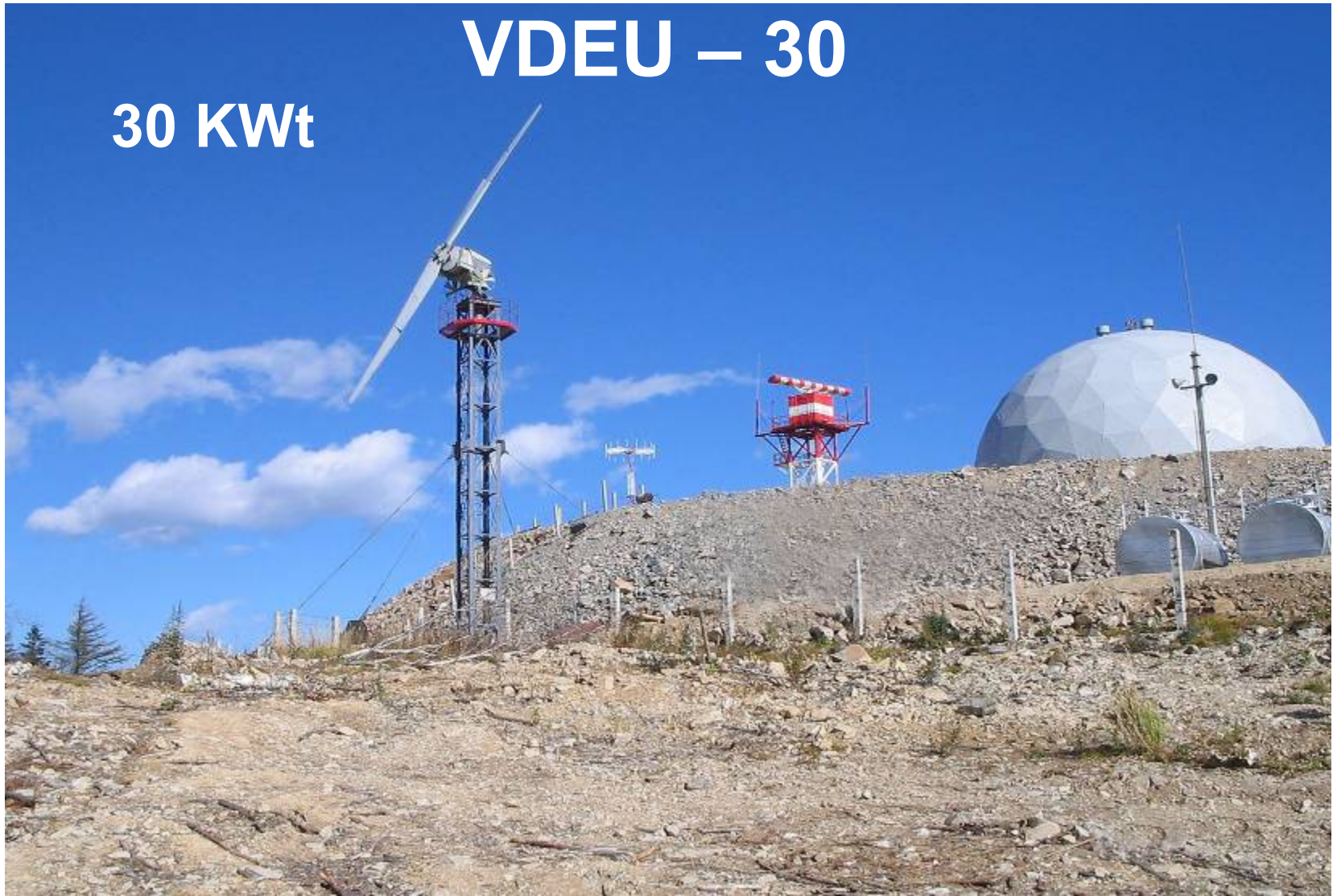

# ENEXIS JSC



$P = 1...5 \text{ kWt}$



# Makeev Design Bureau

**P = 1 and 3 KWt**



# AVIATSIYA Co., Zhukovsky

Modular WE installation  
Modulus power 1 KWt



# WIND ENERGY PROJECT, Moscow

■  $P = 400 \text{ Wt}$

■  $V = 10 \text{ m/s}$

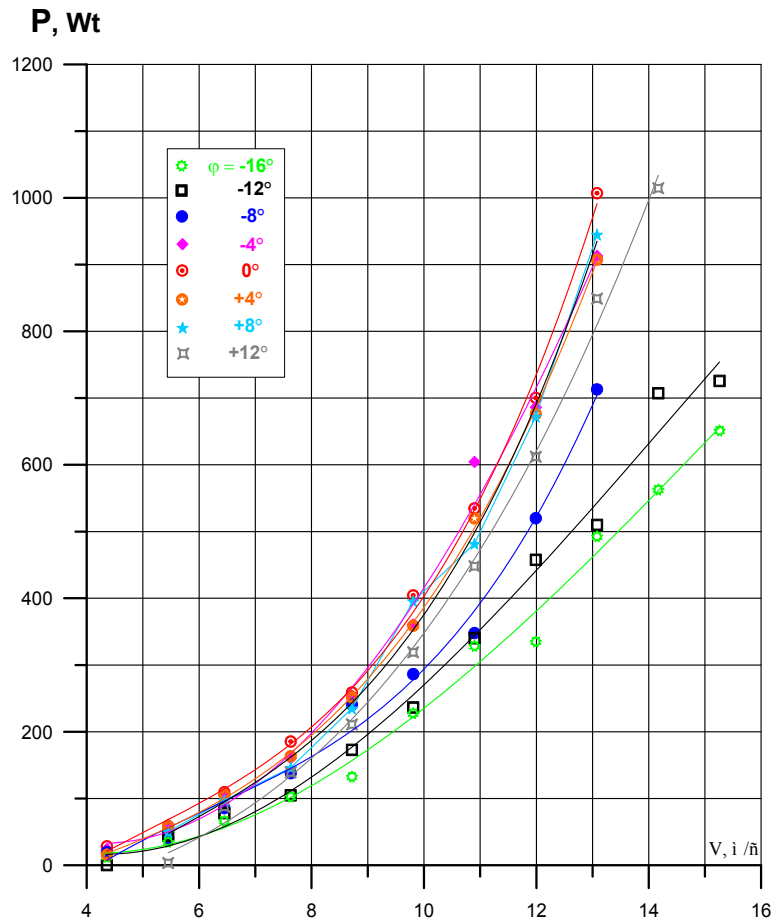



**VEU – 02 WINDEC**



**Far East state  
technical university,  
Vladivostok**

**Wind –solar electric  
power installation**



---

# Requirements for electric generators

- **Low rotation frequencies**
  - **Small starting moments**
  - **Small mass**
  - **High efficiency**
  - **Noncontactivity, manufacturability**
  - **Maintenability**
  - **Low cost**
-

# Electric generators WINDEC Series

## (Magneto electric excitation Nd-Fe-B)

<b>Parameter</b>	<b>ВГ- 02(14)/1500- 14,5-02Г</b>	<b>ВГ- 05(12)/650- 28,5-04 и03Г</b>	<b>ВГ- 1(12)/450(650)- 56(110)-02Г</b>	<b>ВГ- 5(28)/300- 114(56)-02 Г и 02В</b>
<b>Mass, Kg</b>	<b>4,5</b>	<b>9,5/10,5</b>	<b>10.5/19</b>	<b>100</b>
<b>P, KWt</b>	<b>0,2</b>	<b>0,5</b>	<b>1,0</b>	<b>5,0</b>
<b>N rev/min</b>	<b>1500</b>	<b>650</b>	<b>650/425</b>	<b>300</b>
<b>Uload, V</b>	<b>14,5</b>	<b>28/56</b>	<b>56/110</b>	<b>56/110</b>
<b>Efficiency, %</b>	<b>75</b>	<b>83</b>	<b>85</b>	<b>85</b>

# VG -1/450 and VG - 1/650 generators



# Generator parameters

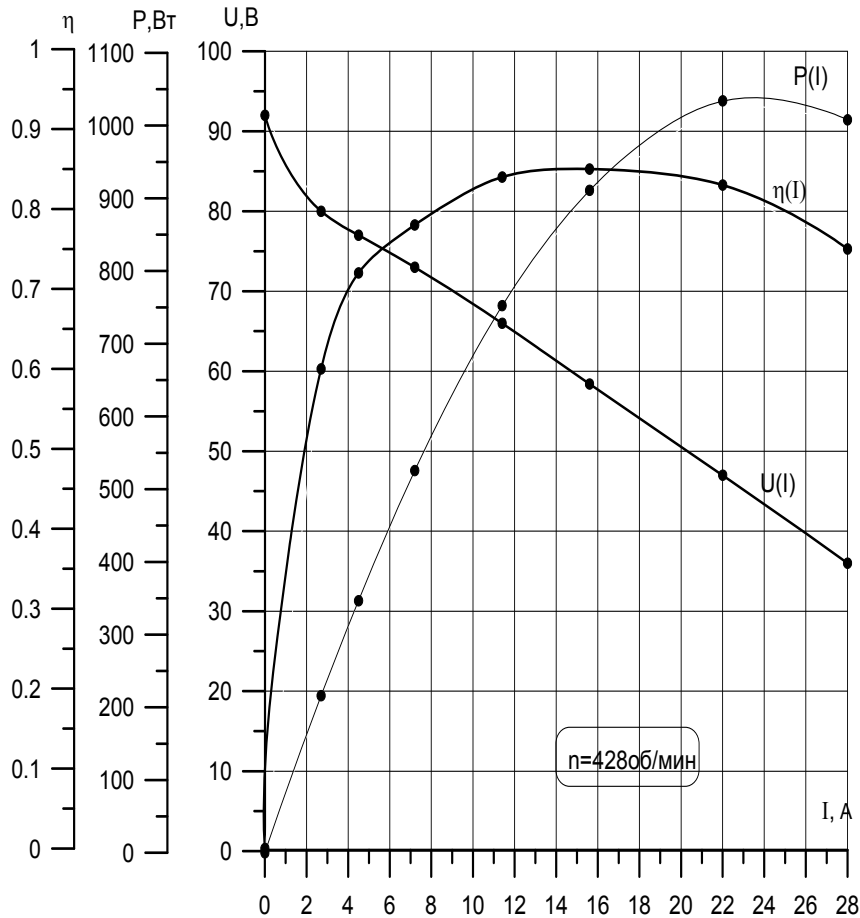

**VG- 1(12) –01**

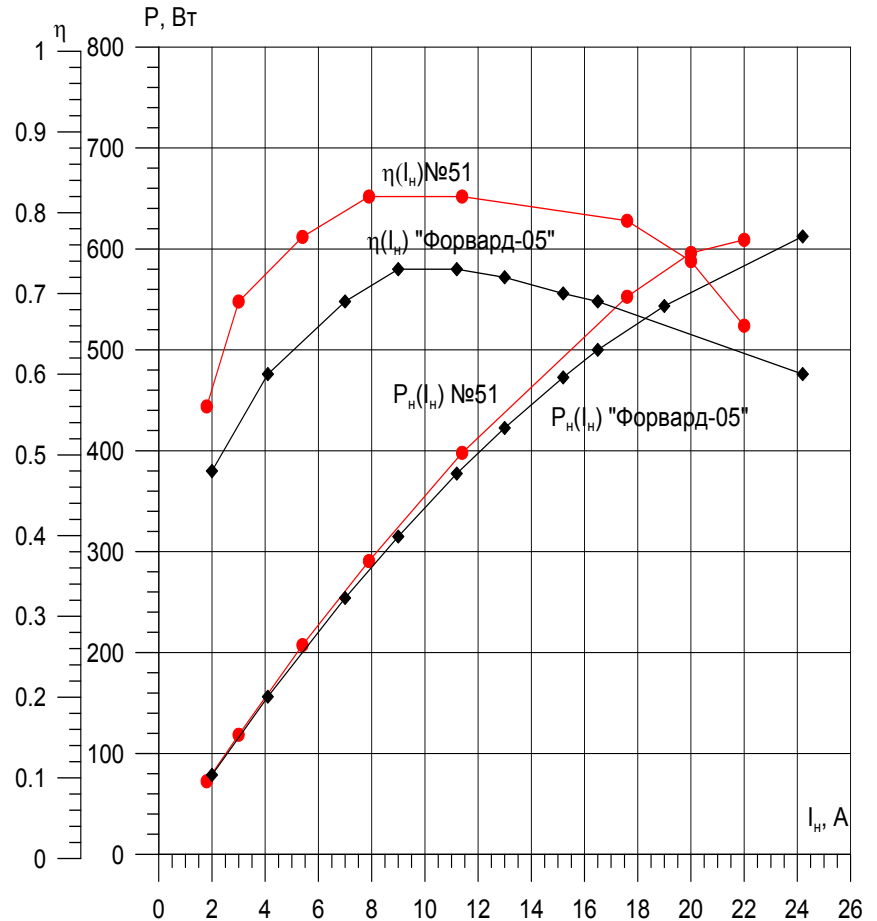

**VG – 05 (12) –04**

# Generator 5 KWt 300 rev/min

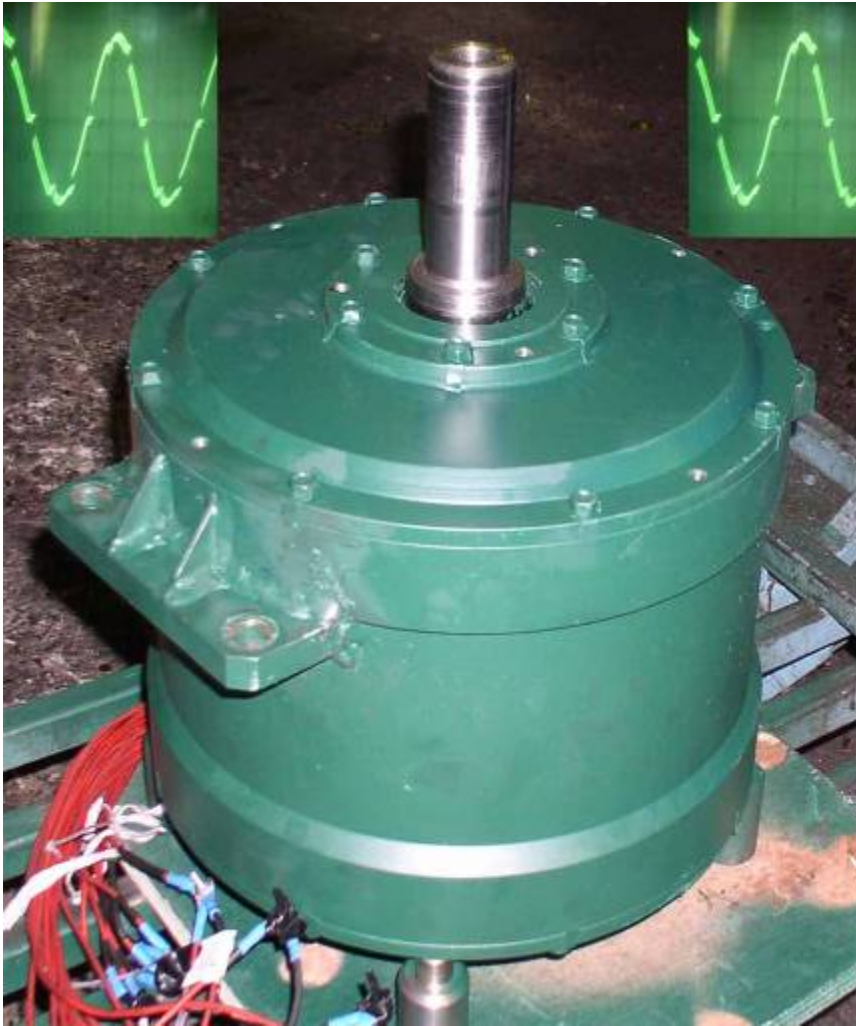

**Rotation speed –  
300 rev/min**

**Mass - 100 Kg**

**Construction:**

- **Horizontal**
- **Vertical**

# Wind generators installed in VEU FORWARD-05



0.5 KWt



0.5 KWt  
1.0 KWt  
5.0 KWt

**VEU SAPSAN**



**VEU WINDEC**

0.2 KWt  
0.8 KWt  
1.0 RWt  
5.0 Kwt



**WINDSPIL - 5**

# WINDEC series generator production program 2007

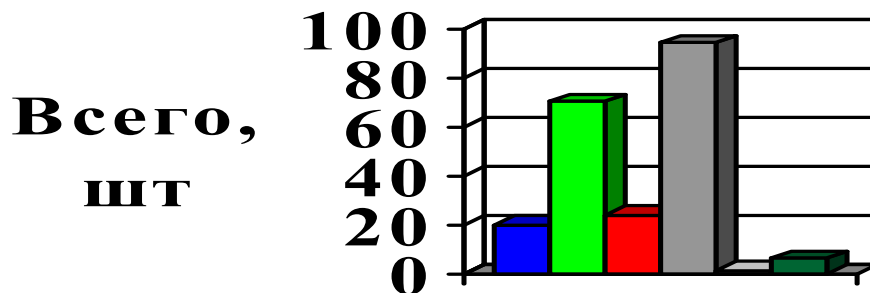
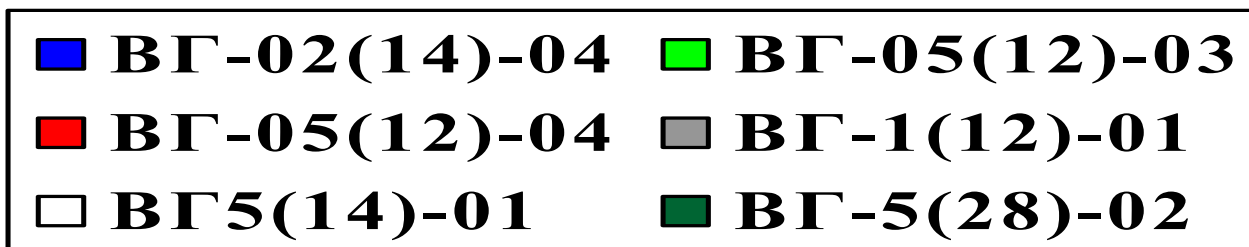

# Generators without starting moment

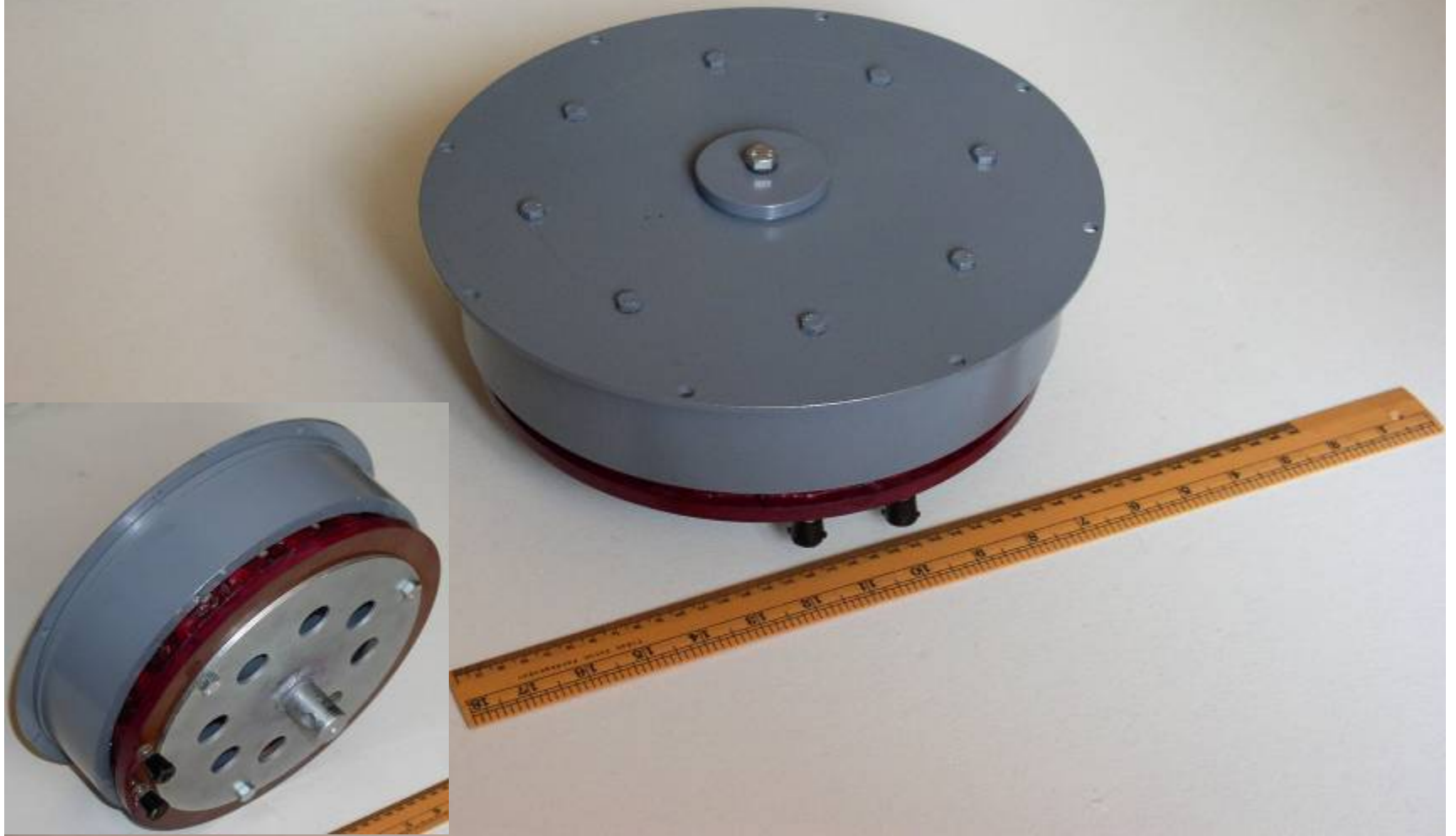

# Magnetic systems of prospect Generators

- Power -5...30 KWt
- Rotation frequency – 30 ...100 rot/min
- Mass – 15-...400 Kg



**GP-15**

**15 KWt**

**100 rot/min**



---

# **Inductor generators**

## **Advantages:**

- 1. Manufacturability**
- 2. Small starting moment**
- 3. Good synchronization**
- 4. Low cost**

## **Disadvantages:**

**Big mass**

---

---

**Thank you!**

**E-mail: [windec@mail.ru](mailto:windec@mail.ru)**

**Web: [windec.mail333.com](http://windec.mail333.com)**

---